

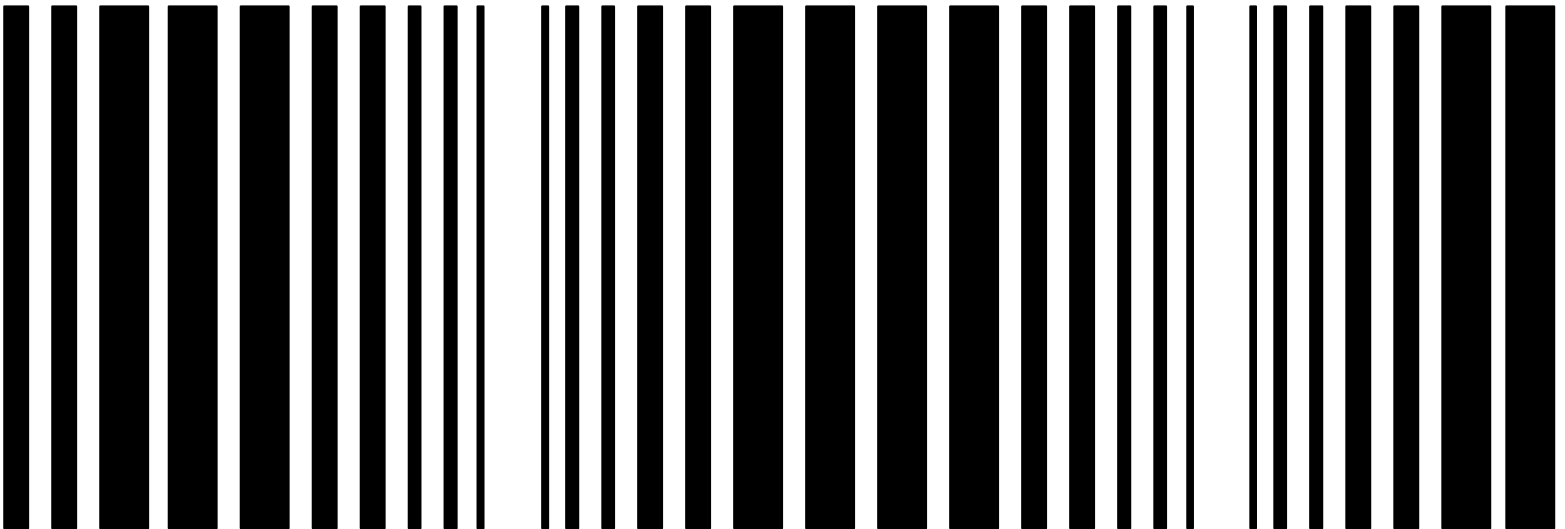

Carbon Bed Fires and the Use of Carbon Canisters for Air Emissions Control on Fixed-Roof Tanks



Carbon Bed Fires and the Use of Carbon Canisters for Air Emissions Control on Fixed-Roof Tanks

Prepared for:

RCRA Program Branch, Region 4
US Environmental Protection Agency
Sam Nunn Atlanta Federal Center
61 Forsyth Street
Atlanta, Georgia 30303-3104

Prepared by:

Research Triangle Institute
P.O. Box 12194
Research Triangle Park, North Carolina 27709

February 2001

This page intentionally left blank.

Disclaimer

The information in the document has been funded by RCRA Programs Branch, Region 4 of the United States Environmental Protection Agency. It has been subjected to the EPA's peer and administrative review, and it has been approved for publication as an EPA document. Mention of trade names or commercial products does not constitute endorsement or recommendation for use by EPA.

This document is not intended, nor can it be relied upon, to create any right enforceable by any party in litigation with the United States. The EPA may change this document at any time without public notice.

When using this document, remember that it is not legally binding and does not replace any applicable Federal regulations such as the "Hazardous Waste Treatment, Storage, and Disposal Facilities and Hazardous Waste Generators; Organic Air Emission Standards for Tanks, Surface Impoundments, and Containers [December 6, 1994 (59 FR 62896) and amended regulations, most recent amendment dated, December 8, 1997 (62 FR 64636)] or any State and local rules that may apply to your facility."

This page intentionally left blank.

Contents

Section	Page
List of Tables	vi
List of Figures	vii
Executive Summary	ES-1
1.0 Use of Carbon Canisters for Control of Air Emissions From Fixed-Roof Tanks	1
2.0 Activated Carbon Ignition and Combustion	3
2.1 Experiments Investigating Activated Carbon Combustion	3
2.2 Characteristics of Carbon Combustion in Carbon Adsorption Systems Used for Solvent Recovery	5
2.3 Acetone Oxidation in Activated Carbon	5
2.4 Prevention of Activated Carbon Bed Ignition and Degradation During the Recovery of Cyclohexanone	6
2.5 Self-heating and Ignition of Chemically Activated Carbon	6
2.6 Oxidation of Methyl Ethyl Ketone and Cyclohexanone on Activated Carbon	7
2.7 Conclusions Regarding Activated Carbon Ignition and Combustion	7
3.0 Carbon Bed Fires in Carbon Adsorption Systems	9
3.1 Bed Fires in Carbon Canisters Used for Air Emission Control	9
3.2 Bed Fires in Carbon Adsorption System Used for Solvent Recovery	10
3.3 Explosion of Fixed-Roof Tank Vented to Carbon Canister	11
4.0 Safety Measures for Carbon Canister Systems	13
4.1 Install Check Valve and Vacuum Breaker Valve	13
4.2 Install Flame Arrester	13
4.3 Install Emergency Pressure Relief Valve	14
4.4 Use Nitrogen Gas Blanket	14
4.5 Pre-Wet Carbon Bed	15
4.6 Use Activated Carbon Type with Higher Ignition Temperatures	15
4.7 Monitor Exhaust Gas Parameters	16
4.8 Carbon Canister Location	16
4.9 Work Practices	16
5.0 Implementation of Safety Measures to Fixed-Roof Tanks	17
6.0 Summary	20
7.0 References	22
Appendix A – Additional Information	A-1
Appendix B – Naujokas’ Tables	B-1

Tables

Number		Page
6-1	Summary of Conditions Contribution to Bed Fires in Carbon Canisters Used to Control Fixed-Roof Tank Air Emissions	20
6-2	Summary of Safe Measures for Carbon Canisters Used to Control Fixed-Roof Tank Air Emissions	21

Figures

Number		Page
1-1	Schematic of a typical carbon canister installation on a fixed-roof tank (without safety devices)	2
5-1	Schematic of carbon canister installations with safety devices, configuration A	19
5-2	Schematic of carbon canister installations with safety devices, configuration B	19

This page intentionally left blank.

Executive Summary

Tanks and containers are commonly used in the waste management industry for the accumulation, storage, and treatment of materials designated under the Resource Conservation and Recovery Act (RCRA) regulations as hazardous waste. Many EPA regulations require control of organic air emissions from tanks and containers that store hazardous waste and other volatile organic liquids. Under subpart CC in 40 CFR parts 264 and 265, the U.S. Environmental Protection Agency (EPA) has established standards requiring the control of volatile organic air emissions from certain tanks located at hazardous waste treatment, storage, and disposal facilities (TSDF). These standards require use of controls depending on the tank design capacity, organic concentration and vapor pressure of the hazardous waste managed in the tank. The subpart CC tank requirements provide compliance options whereby a tank can be vented directly through a closed-vent system to a control device.

Activated carbon adsorption systems are commonly used as control devices to comply with organic air emissions standards for fixed-roof storage tanks. These carbon adsorption air emission controls typically consist of non-regenerable carbon canisters. In some applications and under certain conditions, the activated carbon in a canister can build up heat to the point where the carbon spontaneously ignites in the carbon bed. If safety measures are not in place to contain the fire in the carbon bed, the flame from the carbon bed can propagate back to the tank's vapor space and lead to an explosion inside the tank.

This document discusses why carbon bed fires occur, and what safety measures tank owners and operators can implement to prevent tank explosions should a bed fire occur in their carbon canister control system. Safe operation of carbon canisters begins with eliminating or minimizing the occurrence of bed fires in carbon canisters and installing appropriate safety devices that can confine the fire to the carbon bed and then promptly extinguish it.

This document presents a literature review of laboratory studies investigating the spontaneous ignition of activated carbon when used as an adsorbent and case studies describing conditions contributing to bed fires in carbon adsorption systems at full-scale facilities. General guidance is provided related to safety measures that can be implemented in the design and operation of carbon canisters to reduce the incidence of bed fires and minimize the impact of these fires. The basic set of safety components for carbon canister systems used to control organic air emissions from fixed-roof tanks consists of a backflow check valve, a vacuum breaker relief valve, a flame arrester, and an emergency pressure relief valve. Implementation of additional safety measures may be prudent depending on site-specific conditions.

This page intentionally left blank.

1.0 Use of Carbon Canisters for Control of Air Emissions from Fixed-Roof Tanks¹

Organic air emissions from a fixed-roof tank primarily occur by two emission mechanisms; “working losses” and to a lesser extent, “breathing losses.” When liquids or waste materials containing organics are managed in a fixed-roof tank, some fraction of the organics in the material will volatilize and the vapors collect in the internal volume between the surface of the liquid or other waste material in the tank and the tank roof (i.e., the tank “vapor space”). Working losses result when additional liquid or waste is pumped into the tank and the vapors in the tank vapor space are pushed out of the tank through open vents by the rising waste level. Breathing losses occur when the volume of vapor in the tank vapor space is increased from changes in ambient temperatures or pressure and the vapors flow through the open vents. The quantity of organic emissions from a given tank varies with the concentrations and volatility of the individual organic constituents composing the liquid or waste material managed in the tank.

The typical adsorption process used for controlling tank emissions involves passing an organic vapor-laden gas stream through a packed bed of activated carbon particles. Adsorption takes place when the organic molecules contact the surface of the carbon particles and are selectively held there by attractive forces between the molecules and the carbon particles. A given mass of carbon adsorbs a finite amount of organic molecules. Once the carbon reaches its capacity, the saturated carbon must be regenerated or replaced with fresh carbon before organic emissions control can resume.

Two common types of carbon adsorption systems used for air emission control are carbon canisters and regenerable fixed-beds. Carbon canisters are compact units used to control intermittent gas streams with low-volume flows (typically less than 100 cubic feet per minute). Carbon canister systems are not designed to be desorbed at the facility site once the carbon becomes saturated. A spent canister must be replaced with a new canister containing fresh activated carbon. In contrast, regenerable fixed-bed carbon absorbers are large, multiple-component systems used to treat continuous gas streams with flows ranging from several hundred to several thousand cubic feet per minute. The activated carbon bed is regenerated

at the facility site. These systems are used not only for air pollution control but other industrial applications such as organic solvent recovery.

The intermittent, low vent flows associated with fixed-roof tank working and breathing losses make carbon canisters a particularly suitable and practical control option for tank owners and operators. A schematic of a typical application of a carbon canister to a fixed-roof tank is presented in Figure 1-1. The basic carbon canister system used for fixed-roof tank applications consists primarily of a canister filled with activated carbon and the associated vent piping. For many tank applications, the size of the carbon canister is similar to a drum-type container. Carbon canisters in significantly larger sizes are also available and may be used at some tank facilities. The vapor stream vented from the tank enters at the base of the canister and flows upward through a packed bed of activated carbon particles. The treated gas stream is exhausted through an open pipe at the top of the canister. When the carbon reaches a certain saturation content (typically determined by an engineering calculation of useful life, from operating experience, or less frequently through direct monitoring of the exhaust gas), the canister is disconnected from the tank and replaced with a new one. The spent carbon canister is either disposed of or returned to the vendor (where spent carbon is removed for regeneration and the canister is repacked with fresh carbon).

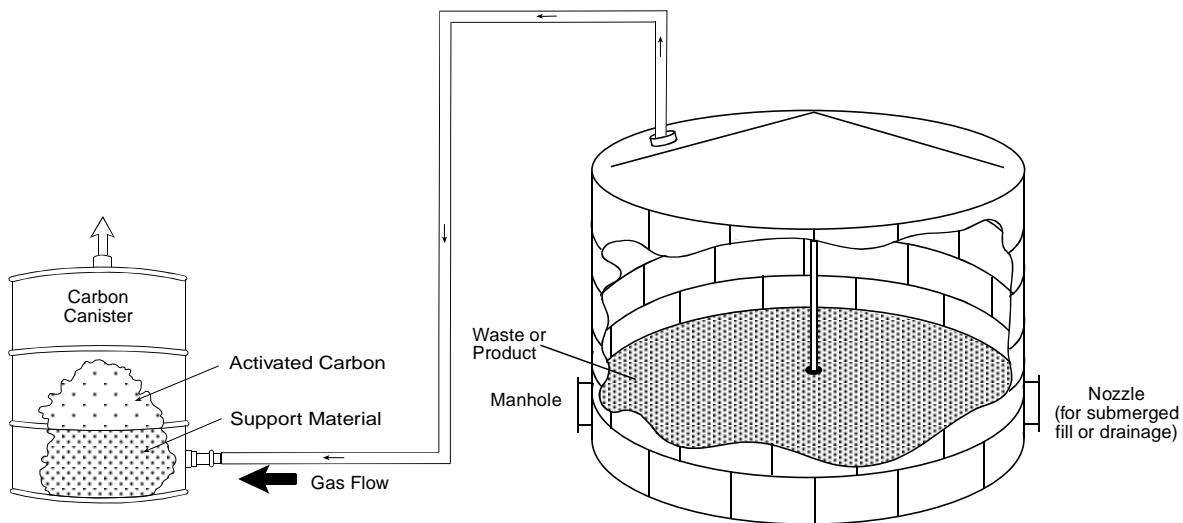

Figure 1-1. Schematic of a typical carbon canister installation on a fixed-roof tank (without safety devices).

2.0 ACTIVATED CARBON IGNITION AND COMBUSTION

Heat is released by the adsorption process when a gas stream containing organic compounds is treated with activated carbon. This heat release (or exotherm) is generated from the adsorption of the organic compounds and the water vapor contained in the untreated gas stream. In addition, certain reactive chemical compounds once adsorbed onto activated carbon undergo chemical oxidation or polymerization on the carbon surface. These reactions are also exothermic. In cases where heat removal is slower than heat generation, temperatures in the carbon bed can rise and potentially reach the ignition temperature of the adsorbed vapors and/or the carbon. This section summarizes the findings of studies investigating the spontaneous ignition and combustion of activated carbon used in carbon adsorption systems.

2.1 Experiments Investigating Activated Carbon Combustion²

Naujokas evaluated the adsorption of various industrial organic compounds to determine which materials oxidize more easily in carbon beds. In one set of experiments, fresh beds of carbon were heated to a temperature of 125 °C using nitrogen gas. Bed temperatures were maintained by thermally insulating the bed's encasement and equipping it with wall heating elements. A stream of nitrogen containing a fixed concentration of vapor was then passed through the bed. When exit gas temperature and composition changes were no longer observed (i.e., when the bed was saturated), the carrier gas was changed from nitrogen to air. (Note that saturating the bed and then maintaining the same inlet concentration to the bed eliminated heat effects due to adsorption.) Bed temperature changes and reaction product emissions (i.e., carbon monoxide and carbon dioxide) were monitored.

Depending on the organic compound, switching the carrier gas from nitrogen to air resulted in either a temperature increase in the bed along with the production of carbon monoxide (indicating that the adsorbed compound was oxidizing), or no change in temperature or carbon monoxide production (indicating that the adsorbed compound was not oxidizing). For example, when ethyl butyl ketone was tested, eighty minutes after the carrier

gas was switched from nitrogen to air for this compound, the temperature in one area of the bed was 600 °C and rising. During this same time interval, carbon monoxide emissions in the exit gas increased from zero to greater than 10,000 ppm.

The Naujokas report provides a summary of the oxidation behavior of 22 organic compounds at a starting temperature of 125 °C. At this temperature, aldehydes, ketones, and organic acids all show high reaction/oxidation rates when the carrier gas is switched from nitrogen to air. Naujokas also provides a summary of the oxidation behavior of 10 organic compounds at starting temperatures of 100 °C. At this lower temperature, the reaction rates of ketones and organic acids decrease markedly, while the reaction rates of aldehydes remain high (i.e., they were unchanged relative to the values at 125 °C). See Appendix B for the list of compounds tested and their reaction rates.

In a second set of experiments, a bed of activated carbon was saturated with air containing methyl ethyl ketone at a temperature of 40 °C. Once the bed was saturated, the gas flow was stopped. A small air bleed was then introduced upstream of the carbon to supply oxygen for oxidation. Bed temperature changes and reaction product emissions were monitored. At an air bleed velocity of 0.2 cm/sec, hot spots in the carbon were observed and carbon monoxide and carbon dioxide emissions increased from zero to 8,000 and 6,000 ppm, respectively. At an air bleed velocity above 0.35 cm/sec, hot spots were not observed indicating that convective heat transport exceeded the heat generation rate. When no air bleed was used, hot spots did not develop indicating insufficient air/oxygen was available for oxidation. When natural convection (i.e., air flow) was allowed, hot spots and carbon monoxide and carbon dioxide emissions were produced similar to those with forced convection. In experiments using humidified air (60 to 65 percent relative humidity) hot spots developed several hours later than with dry air.

In a third set of experiments, Naujokas found that increasing air velocity across an existing hot spot can lead to bed combustion if the temperature of the hot spot is high enough. In one experiment, Naujokas increased the air velocity from 0.2 cm/sec to 10 cm/sec across a hot spot at 200 °C (the bed was saturated with methyl ethyl ketone). Within 6 minutes, the hot spot temperature was at 376 °C and rising, and ultimately resulted in bed combustion. Similar results were obtained when the temperature of the hot spot was between 160 and 300 °C, and the air velocity was increased to 50 cm/sec.

In addition, Naujokas found that oxidation reactions vary depending on the type of carbon used. In particular, Naujokas found that reactive compounds oxidize more readily on coconut-based carbon compared to coal or petroleum-based carbon. Carbon that has been in service for some time was also found to be conducive to oxidation. Under identical experimental conditions, oxidation rates of acetone were greater on previously used carbon

compared to fresh carbon. Similar results were seen with methyl ethyl ketone and other compounds.

2.2 Characteristics of Carbon Combustion in Carbon Adsorption Systems Used for Solvent Recovery³

The authors discuss the common characteristics of carbon fires in regenerable fixed-bed carbon adsorption systems used for recovery of ketones, aldehydes, or similar compounds. The authors found that prior to the carbon fire occurring, these carbon adsorption systems usually had been shut down for a few days due to production schedules, mechanical failures, or other circumstances. The bed fires occurred when the adsorption cycle was restarted (i.e., when the air/vapor stream was reintroduced to the bed). Smisek and Cerny attribute these fires to the spontaneous oxidation of carbon, which occurs when an insufficiently dried and cooled adsorber is shut off. During shut down, air can be drawn into the adsorber through the imperfectly sealed walls of the adsorber; the air is sufficient to maintain the oxidation process, and since the heat evolved from this oxidation is only slowly removed, the carbon may be locally heated to the temperature of self-ignition. Self-ignition can also be aided by the oxidation of residues of the incompletely desorbed solvents, for instance, the oxidation of acetone to acetic acid. If hot spots exist when the adsorber is restarted, the sudden increase in air/oxygen can lead to a fire. According to Smisek and Cerny, the hazard of self-ignition can be avoided by thoroughly drying the adsorber and cooling it to about 40 °C before it is shut down.

In addition, the authors noted that during the adsorption cycle the temperature of the activated carbon is increased somewhat by the heat of adsorption, but the increase is not considered significant and under normal conditions would not lead to self-ignition. Also, they state that desorption at temperatures below 120 °C does not cause fires; however, desorption at higher temperatures (up to 200 °C), which is done to increase system capacity, is of concern as localized heating may occur that can lead to ignition during drying with hot air.

2.3 Acetone Oxidation in Activated Carbon⁴

This study investigated the oxidation of the ketone acetone adsorbed on activated carbon, and the effect of the oxidation on carbon combustion. The investigator found that adsorbed acetone begins to oxidize rapidly at 80 °C. When the heat released from acetone oxidation at 80 °C was not dissipated from the bed, the reaction manifested itself by increasing bed temperatures, eventually reaching the ignition temperature of the commercial coconut shell carbon used in this study (i.e., 240 °C, as established using a technique described in the

paper). The study notes that bed fires have their origins in regions of low air flow, thereafter developing with increasing air availability. In low air flow applications, the heat released from oxidation can exceed the heat dissipated by the flow. The resulting heat imbalance creates a temperature rise in the bed, which in turn accelerates oxidation rates.

The study also points out that even in applications where sufficient gas stream flow exists to cool the bed, heat imbalances can arise if “dead spots” are present in the carbon bed. A dead spot is a pocket of carbon through which little or no air flow passes. Dead spots can result from channeling of the gas or from carbon breakdown. (Carbon breakdown is more common in regenerable fixed-bed carbon adsorption systems where the repeated adsorption then regeneration cycle causes the carbon to physically break down into regions of tightly packed carbon granules and dust.) Since little gas flow passes through a dead spot, the heat generated from adsorption or oxidation is not adequately dissipated. As a result, the hot spot can increase in temperature until it reaches the ignition point of the adsorbed organics or the carbon.

2.4 Prevention of Activated Carbon Bed Ignition and Degradation During the Recovery of Cyclohexanone ⁵

Takeuchi investigated oxidation of the ketone cyclohexanone adsorbed on activated carbon, and the effect of oxidation on carbon combustion. The study found that oxidation of adsorbed cyclohexanone was largely responsible for carbon bed ignition. Based on the research, effective measures identified for preventing bed fires included weathering or aging of the carbon (oxidation rates were higher on fresh carbon versus carbon that had been aged for two years, the opposite of Naujokas’ findings), removing ash from the carbon, and adding a small amount of moisture to the incoming gas stream (i.e., the moisture in the carrier gas helps prevent the carbon bed from over heating; moisture of only about 5 percent relative humidity was found to be effective in avoiding ignition). The authors also recommended that the contact of activated carbon with oxygen be avoided after drying and that a supply of inert gas, such as nitrogen, be used to cool the bed.

2.5 Self-Heating and Ignition of Chemically Activated Carbon ⁶

This study found that newly manufactured activated carbon undergoes appreciable exothermic reactions upon initial exposure to air at ambient temperatures. The exothermic reactions, which are due to rapid adsorption of oxygen and moisture, are largely completed in a period of a few minutes to a few hours. In contrast, the authors found that long-term

self-heating of activated carbon is mainly due oxidation of the carbon. The oxidation is relatively slow and can continue for weeks following manufacture. The self-heating process is sensitive to carbon activation conditions and exposure to air at high temperatures (e.g., 100 °C). They also confirmed that the increase in carbon temperature associated with self-heating depends on the balance between the rate at which heat is generated by adsorption/oxidation and the rate at which heat is lost to the surroundings.

2.6 Oxidation of Methyl Ethyl Ketone and Cyclohexanone on Activated Carbon⁷

Henning investigated the surface oxidation of methyl ethyl ketone and cyclohexanone on three types of activated carbon (lignin-based, peat-based, and hard coal-based carbons). The study found that both of these ketones, even in the adsorbed state, oxidize on the surface of activated carbon due to the presence of oxygen. The effects of temperature, carbon type, and ash content on oxidation were also investigated. The following are some of the conclusions/findings from the study:

- To minimize surface reactions, a low adsorption temperature is more important than the type of activated carbon being used.
- Adsorption temperature should not exceed 30 °C for methyl ethyl ketone and cyclohexanone since surface reactions of the two ketones increase exponentially above this temperature.
- A flow velocity of at least 0.2 m/s should be used to dissipate the heat of adsorption.
- Oxidation reactions are higher on carbons treated to remove ash content versus untreated carbons. The authors note that this finding is interesting, since other published literature suggests that ash content promotes oxidation reactions.

2.7 Conclusions Regarding Activated Carbon Ignition and Combustion

Based on the information reviewed, the following conclusions are made regarding the conditions contributing to the spontaneous ignition and combustion of activated carbon.

- Activated carbon adsorption is an exothermic process. The amount of heat release from activated carbon adsorption is a function of the following properties of the gas stream being treated: gas flow rate, concentration of the gaseous contaminants, relative humidity of the gas stream, and presence of certain reactive compounds.
- For certain classes of chemical compounds, adsorption and oxidation on the activated carbon surface can release a significant amount of heat, particularly if the chemicals are present at high concentrations in the gas stream. Most carbon adsorption system bed fires described in the literature reviewed have occurred in systems treating gas streams containing oxygenated hydrocarbons, but chemicals other than these can also burn on activated carbon. Chemical compounds of concern include ketones, aldehydes, certain organic acids (e.g., propanoic acid and butyric acid), and organic sulfur compounds (e.g., mercaptans).
- Under certain conditions, carbon adsorption reactions can release sufficient quantities of heat to increase the temperatures in a carbon bed to the spontaneous ignition point whereby combustion of the activated carbon occurs.
- The type of activated carbon used and the condition of the carbon are important factors contributing to the carbon's ignition temperature.
- For most carbon adsorption systems, heat transfer through the carbon bed vessel walls is small. Consequently the primary heat transfer mechanism for removing heat released by adsorption and oxidation from the carbon bed is by convective transport in the gas stream passing through the carbon bed.
- Hot spots occur in the carbon bed when the heat generated by adsorption and oxidation reactions exceeds the heat removed by convection. Channeling of the gas flow around pockets of carbon can also contribute to a heat imbalance in the carbon bed.
- Carbon bed fires occur when hot spots in the carbon reach the ignition temperature of the adsorbed vapors and/or activated carbon itself, and sufficient oxygen is present to sustain combustion of the carbon and adsorbed compounds. Reported ignition temperatures for activated carbon typically range from less than 300 °C to over 600 °C.⁸
- The typical vapor stream flow from a fixed-roof tank is intermittent and at relatively low flow rates. Under these conditions, gas stream flow through a carbon canister may be insufficient to dissipate heat adequately when the gas is composed of highly reactive organic compounds and/or high concentrations of organics.

3.0 Carbon Bed Fires in Carbon Adsorption Systems

Bed fires in carbon adsorption systems are not uncommon and can present a real safety hazard at facilities if proper precautions are not implemented. In at least one case, discussed below, the explosion of a tank using a carbon canister for air emission control is attributed to the flashback of the flame from a carbon bed fire. The following is a summary of experiences at three facilities in addressing carbon bed fires in their carbon adsorption systems.

3.1 Bed Fires in Carbon Canisters Used for Air Emission Control⁹

An organic chemical manufacturing facility experienced several bed fires associated with carbon canisters used to control air emissions from fixed-roof tanks containing crude sulfate turpentine. The fixed-roof tanks were configured as shown in Figure 1-1. A single vent on the tank roof was connected to a carbon canister via a hose with no check valve to prevent back flow. When the tank was emptied or when the liquid in the tank cooled, negative pressure conditions (i.e., a vacuum) developed in the tank vapor space which pulled in ambient air through the carbon canister. It was reported that fires frequently occurred at night following a hot day. In one particular case, the daytime temperature was 95 °F or more, and the tank was exposed to full sunlight. The temperature within the tank increased to 135 °F, causing the liquid to expand and vaporize, and forcing the vapor-laden air out of the tank and to the carbon canister. In the evening, when the tank had cooled, the vapor in the tank's head space condensed creating a pressure gradient or slight vacuum in the tank. As the ambient air was drawn into the tank through the carbon canister, the hot organic molecules adsorbed on the carbon oxidized/combusted (due to the presence of oxygen) resulting in the bed fire.

To address the problem with carbon bed fires, the company installed a check valve in the vapor line between the tank and the carbon canister. This valve prevented back flow of ambient air through the carbon bed. A vacuum breaker was installed upstream of the check valve to allow ambient air to flow directly into the tank vapor space when necessary to maintain the internal tank pressure within the tank design pressure range. These modifications removed the path by which ambient air could be drawn into the tank through the carbon canister and reduced the exposure of the bed carbon to an oxygen source.

Although these modifications did not completely eliminate the carbon bed fires, the incidence of carbon bed fires at the facility was significantly reduced.

3.2 Bed Fires in Carbon Adsorption System Used for Solvent Recovery¹⁰

A graphics company experienced three serious bed fires in a regenerable, fixed-bed carbon adsorption system used for solvent recovery of ketones. This type of carbon adsorption system is much larger than many carbon canisters. To address the problem the company consulted with equipment vendors, carbon suppliers, consultants, insurance carriers, and other users of carbon bed adsorption equipment. Most people contacted believed that the bed fires were a result of a heat imbalance due to the high heat of adsorption of the ketones. The recommended measure to correct this heat imbalance was to keep the carbon beds moist. Adding moisture to the carbon beds allowed the latent heat of vaporization of water to dissipate the heat of adsorption of the ketones. To keep the beds moist, various “fixes” were recommended, including extension of steaming cycles, increased steam flow-rates, increased steaming times at start-up and shutdown, desuperheating the steam, and humidification of solvent laden air inlet streams. The company followed these recommendations but still encountered subsequent bed fires.

Facility personnel noted that the fires never took place during an extended adsorption cycle but only occurred during start-up following a weekend shutdown. They believed the fires resulted from a heat imbalance during shut down when solvent-laden air was not cooling the bed, which allowed the oxidation of adsorbed ketones to accelerate and form localized hot spots. Bed combustion occurred when the adsorption cycle was restarted (i.e., when the air/vapor stream was reintroduced to the bed).

Based on the facility’s experience with carbon bed fires, the facility personnel prepared a list of minimum requirements for any carbon bed adsorption system in ketone service. Foremost among the recommendations is that, to operate a carbon bed adsorber safely in ketone service, there must be a means of monitoring the process and its propensity for ignition. They concluded that the parameters to provide this information are on-line, real-time monitoring of CO and/or CO₂ concentrations in the exhaust gas stream from the carbon bed when the system is operating in the adsorb mode and in the bed at all other times. For these large-scale systems, safe operation requires that the monitoring equipment be maintained and operated continuously whether the unit is on-line or off-line.

3.3 Explosion of Fixed-Roof Tank Vented to Carbon Canister¹¹

On January 15, 1998, a fixed-roof tank vented to a carbon canister exploded at a facility in Sumter, South Carolina. The tank was used to store a mixture of lacquers and thinners that contained acetone, methyl ethyl ketone, and toluene. At the time of the incident, the tank was configured with a fixed roof like that shown in Figure 1-1. A single vent on the tank roof was connected to the carbon canister by a pipe with no check valve. The facility personnel concluded that the most plausible explanation for the tank explosion was that localized heat of adsorption and reaction in the carbon canister provided sufficient thermal energy to reach the ignition temperature of the flammable vapor in the piping. Because no safety devices were in place to prevent back flow to the tank, the fire in the carbon bed flashed back through the piping to the vapor space in the tank.

Operating history showed that the facility had never experienced a tank explosion prior to the installation of the carbon canisters. Following the incident, facility personnel measured the bed temperature in the carbon canisters used on other tanks and recorded readings in the range from 120 to 150 °F. While these temperatures were well below the auto ignition temperature of the organic vapors, according to the canister manufacturer it was possible to have localized hot-spots in the carbon bed with temperatures significantly higher than those measured. These hot spots could have ignited the vapor. Given the tank was used to store solvents containing ketones and other highly reactive compounds and the tank configuration, the carbon canister manufacturer agreed with facility personnel that it was feasible that hot spots in the carbon bed ignited the vapor in the gas stream which flashed back through the vent piping to the tank.

To prevent the recurrence of another tank explosion, the following safety measures were implemented at the facility for each tank vented through a carbon canister. A check valve was installed in the vapor line to prevent vapor or liquid back-flow from the carbon canister into the tank. A vacuum breaker valve was also installed upstream of each check valve to prevent collapsing the tank when pumping liquid out of the tank. An inline flame arrester was installed in the vapor line between the tank and the check valve. Metered nitrogen gas was used as an inert blanket for the atmosphere in the tank and in the vapor line. The facility reports that since making these changes to carbon canister systems, no tank explosions have occurred.

This page intentionally left blank.

4.0 Safety Measures for Carbon Canister Systems ^{12,13,14,15}

As discussed in the preceding section, facilities have implemented a number of different safety measures to reduce carbon bed fires and to prevent large scale collateral effects should a bed fire occur. Described below are the different types of safety measures. This section concludes with a discussion of how these safety measures can be implemented on carbon canister systems used to control fixed-roof tank air emissions

4.1 Install Check Valve and Vacuum Breaker Valve

A check valve is a valve that automatically limits gas (or liquid) flow in a pipe to one direction. Installing a check valve in the carbon canister system line prevents ambient air from back flowing through the cannister outlet into the canister and passing over the carbon bed when negative pressure develops in the tank vapor space due to cooling at night or when liquid is withdrawn from the tank.

With the installation of a check valve in the carbon canister system, a vacuum breaker valve (sometimes referred to as a vacuum relief valve) must also be installed. A vacuum breaker valve is a one-way valve that opens automatically at a preset pressure allowing ambient air to flow into the tank. When the internal pressure of the tank adjusts to a prescribed pressure setting, the valve automatically closes and air no longer flows into the tank. The vacuum breaker valve is needed to prevent the tank from collapsing inwardly when negative pressure develops in the tank vapor space due to cooling at night or when liquid is withdrawn from the tank. The vacuum breaker valve opens only in situations when vacuum relief is required to protect the tank or canister. Organic vapors from the tank cannot flow out through the valve. In some cases, the vacuum breaker valve is connected to a nitrogen tank to provide additional fire protection (described later in this section).

4.2 Install Flame Arrester

A flame arrester is a device that prevents the propagation and transmission of a flame or flame front in locations where flammable vapor/air or gas mixtures are present. Flame

arresters are available in a number of different configurations (parallel rectangular metal plate, wound crimped metal, parallel round metal plate). One common feature of all flame arresters is that the flammable vapor mixture is forced to pass through a series of small openings as it flows through the arrester. The size of the openings and their length of passage can vary, depending on the arrester style. If a flammable vapor should ignite, the flame burns towards the arrester/element. As the flame attempts to pass through the element, it is slowed and cooled by contact with the metal walls of the small passages. Heat is transferred to the element until combustion cannot be maintained. The flame front is then extinguished.

4.3 Install Emergency Pressure Relief Valve

A pressure relief valve is a device that opens automatically at a preset pressure allowing vapors to flow out of the tank. When the internal pressure of the tank adjusts to a prescribed pressure setting, the valve automatically closes and vapors are no longer vented from the tank. An emergency pressure relief valve is a safety device that vents the tank vapor space directly to the atmosphere any time needed to prevent physical damage or permanent deformation to the tank due to unsafe conditions resulting from an unplanned, accidental, or emergency event. This valve is not used for venting of gases or vapors from the tank during normal operations. An emergency pressure relief valve protects the tank should vapor flow through carbon canister bed become partially or completely restricted because the bed becomes blocked or plugged. In such an emergency situation, the pressure-relief valve will open and thereby relieve the tank's internal pressure until a safe level is attained.

4.4 Use Nitrogen Gas Blanket

An inert gas (in this case nitrogen) can be used in place of ambient air as the source of make-up gas for a vacuum breaker valve. Using nitrogen gas in place of ambient air provides a nonflammable atmosphere in the vapor space and vapor line of a fixed-roof tank. Being an inert gas, nitrogen is nonflammable and usually chemically non-reactive when mixed with the organic vapors in the tank. The nitrogen gas eliminates or reduces the oxygen available for combustion. Nitrogen can be used as the primary make-up gas for the vacuum breaker (in which no ambient air enters the system), or it can be used in conjunction with ambient air. In the latter case, the amount of nitrogen gas added is such that the concentration of oxygen in the air is too low to sustain combustion.

4.5 Pre-Wet Carbon Bed

Two carbon manufacturers discuss pre-wetting the carbon as a means to avoid bed fires. According to Calgon,¹⁶ pre-wetting the carbon helps dissipate excessive heat. Carbtrol¹⁷ recommends pre-wetting the carbon when the reaction of the contaminated gas stream is unknown, a situation that is more likely to occur when dealing with wastes containing volatile organics, especially when those wastes are received from off-site generators. The Carbtrol literature describes how the carbon should be wetted.¹⁸

4.6 Use Activated Carbon Type with Higher Ignition Temperatures

Activated carbon can be made from a variety of materials including coconut shells, wood, bituminous coal, and other organic materials. A coconut-based activated carbon is the most common type of carbon used for air pollution control applications. Different types of activated carbon have different ignition temperatures and ash contents (in some cases, a high percentage of ash content promotes carbon bed ignition). For applications where the tank vapor stream to be controlled contains reactive organics, selection of an activated carbon with a high ignition temperature and a low ash content may help avoid carbon bed fires. The ignition temperatures of coal-derived activated carbons are generally around 450 °C¹⁹. Lignin-based carbon generally has an ash content of around 15 percent ash, whereas bituminous-based carbon has an ash content from 5 to 10 percent.²⁰ Ash contents can be lowered by washing the carbon with acid during the manufacturing process. In contrast, the ignition temperatures of coconut-derived activated carbons generally range from 280 to 300 °C²¹, and generally have ash contents less than 2 percent. It is of interest to note that Naujokas found that reactive compounds oxidized more readily on coconut-based carbon compared to coal- or petroleum-based carbons. Hassler points out that comparisons of ignition temperatures for different carbons are of significance only when determined under identical experimental conditions. The various methods may not show identical ignition temperatures for a particular carbon because the temperature at which carbon ignites in air is influenced by the experimental conditions⁸.

4.7 Monitor Exhaust Gas Parameters

Large carbon bed systems, such as those used for solvent recovery, are often equipped with sensors for monitoring temperatures in different parts of the carbon bed as well as in the exhaust gas. Some systems also have instruments for detecting carbon monoxide and carbon dioxide (products of oxidation) in the exhaust gas. These built-in monitoring devices are less likely to be used on carbon canister systems because the beds are frequently replaced due to their small size. One carbon manufacturer, Carbtrol,²² recommends monitoring the exhaust temperature during the first 24 hours of operation of a canister. According to Carbtrol, a rise in the gas temperature of greater than 50 °F is an indication of excess heat generation. Under these conditions, the unit should be removed from service and the cause of the excessive heat generation should be determined.

4.8 Carbon Canister Location

The carbon canister should be located where it can be easily accessed for removal or replacement. Preferably, the carbon canister should be placed at ground level where readily visible to facility personnel and in a location that is physically isolated from the tank that vents to it. The carbon canister should be situated with open space between it and major pieces of equipment or tanks.

4.9 Work Practices

At initial startup of a new carbon canister, facility personnel should closely monitor the first hours of operation periodically measuring temperature and/or CO/CO₂ levels in the gas stream exhausted from the canister. Increasing temperature and CO/CO₂ levels in the gas stream provide early warnings of excessive heat buildup or combustion problems in the unit.

Air leaks in valves, fittings, and other carbon canister system components can provide additional sources of oxygen to the carbon bed and help promote oxidation reactions. Facility personnel should periodically inspect and maintain valves and other system components to minimize openings by which air can be pulled into the carbon bed.

Facility personnel should be trained to respond rapidly to a carbon bed fire. They should know how to disconnect the canister quickly from the vapor line and how to extinguish the fire. Once the canister is disconnected, the unit can be moved to an open area away from the tank. Overhead deluging of the carbon bed with water has been found to be an effective means for extinguishing the fire.

5.0 Implementation of Safety Measures to Fixed Roof Tanks

Carbon canisters can safely be used to control organic air emissions from fixed-roof tanks provided appropriate safety measures are employed. The set of carbon canister safety measures used for a specific fixed-roof application will depend on site-specific conditions and preferences of the tank owner or operator. Not all of the safety measures described above necessarily need to be implemented at a given tank site. This section presents general guidance that the tank owners and operators should consider in the design and operation of the carbon canisters used for their specific tank applications. However, because of the wide variety of tank applications that potentially can be controlled using carbon canisters, a definitive list of the specific organic constituents, concentrations, temperatures, and other properties associated with activated carbon bed fires cannot be provided in this paper. Tank owners and operators should always discuss their site-specific conditions with the carbon canister manufacturer or vendor prior to installation of a carbon canister to ensure that adequate safety measures are implemented.

Safe operation of carbon canisters begins with eliminating or minimizing, to the extent possible, the occurrence of bed fires in carbon canisters. The first step in selecting the combination of safety measures appropriate for a given fixed-roof tank applications is to gather information to characterize the tank vapor stream to be controlled by the carbon canister. Useful vapor stream information includes the organic chemical constituent composition and concentrations, flow rates, temperatures, and relative humidity. This information is used to predict the likelihood of potential heat buildup problems occurring in the carbon bed because of the presence of reactive compounds, high organic concentration loadings, or inadequate gas stream flow. Should this be the case, then the system design needs to be considered in greater detail. The system design may need to be modified to use a type of activated carbon with high ignition temperature. In cases where the nature of the tank vapor stream to be controlled is such that the likelihood of a bed fire is reasonable, appropriate safety measures should be incorporated into the system design to detect and extinguish bed fires promptly. For example, an exhaust gas temperature monitor with an audible alarm can be installed to alert facility personnel of a bed fire. As an additional precaution, when conditions warrant, the carbon canister can be equipped with a fire suppressant system (such as water flood or spray systems).

In cases when adequate information to characterize the gas stream is unavailable, then appropriate precautions should be followed at initial startup of the carbon canister system. For example, the temperature of the exhaust gas from the carbon canister can be monitored while maintaining a continuous gas flow through the canister for the first few hours of operation. An increase in the gas temperature indicates excessive heat generation or heat buildup. In addition, pre-wetting the carbon will reduce the likelihood of a bed fire should a problem occur.

Safety measures should also be implemented to prevent large scale collateral effects should problems arise. Should gas flow restrictions in the carbon bed increase internal tank pressures (e.g., openings in the canister become blocked or plugged), rupture of the tank can be prevented by installing emergency pressure relief devices. Should a fire occur in the carbon bed, tank explosions can be prevented by installing appropriate safety devices to confine the fire to the carbon bed and prevent flashback to the tank.

Implementation of one or more additional safety measures may be prudent to address site-specific tank conditions. The basic set of safety components consists of a backflow check valve, a vacuum breaker relief valve, a flame arrester, and an emergency pressure relief valve.

These safety components can be installed in a number of different configurations. Figures 5-1 and 5-2 present two of the possible installation configurations. The backflow check valve can be installed in the exhaust outlet for the carbon canister (Figure 5-1) or in the vent line between the tank and the carbon canister (Figure 5-2) depending on preference. For a check valve installed on the outlet to the carbon canister to be effective, it is important to ensure that there are no air leaks in the carbon canister vessel or its connections. In addition, if the backflow check valve is mounted on the canister exhaust, the vacuum breaker must be set at a pressure that takes into consideration both the tank's and the canister's structural design. This prevents situations where the canister could collapse if the vacuum breaker is set for the tank rather than the canister (assuming the tank is stronger than the canister). The vacuum breaker relief valve can be installed in the vent line between the tank and the carbon canister as shown in Figures 5-1 and 5-2 or directly on the tank. Another variation is to connect the vacuum breaker relief valve to a nitrogen tank to serve as the source vacuum make-up gas. The flame arrester is installed in the vent line between the tank and the carbon canister. Care should be taken in determining the type and location of the flame arrester. The flame arrester should be mounted as near as practicable to the canister (i.e., the potential point of ignition). If placed too far from the canister, the flame can accelerate sufficiently through the vent pipe to cause the arrester to fail²³. For fixed-roof tank applications, emergency pressure relief valves are normally installed on the tank roof.

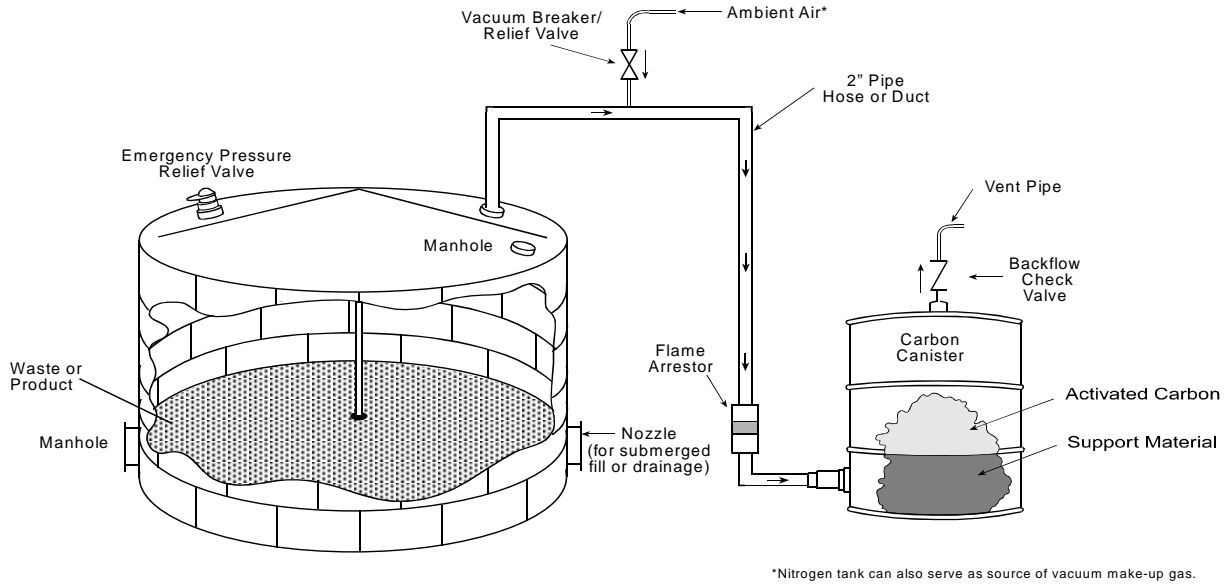

Figure 5-1. Schematic of carbon canister installations with safety devices, configuration A.

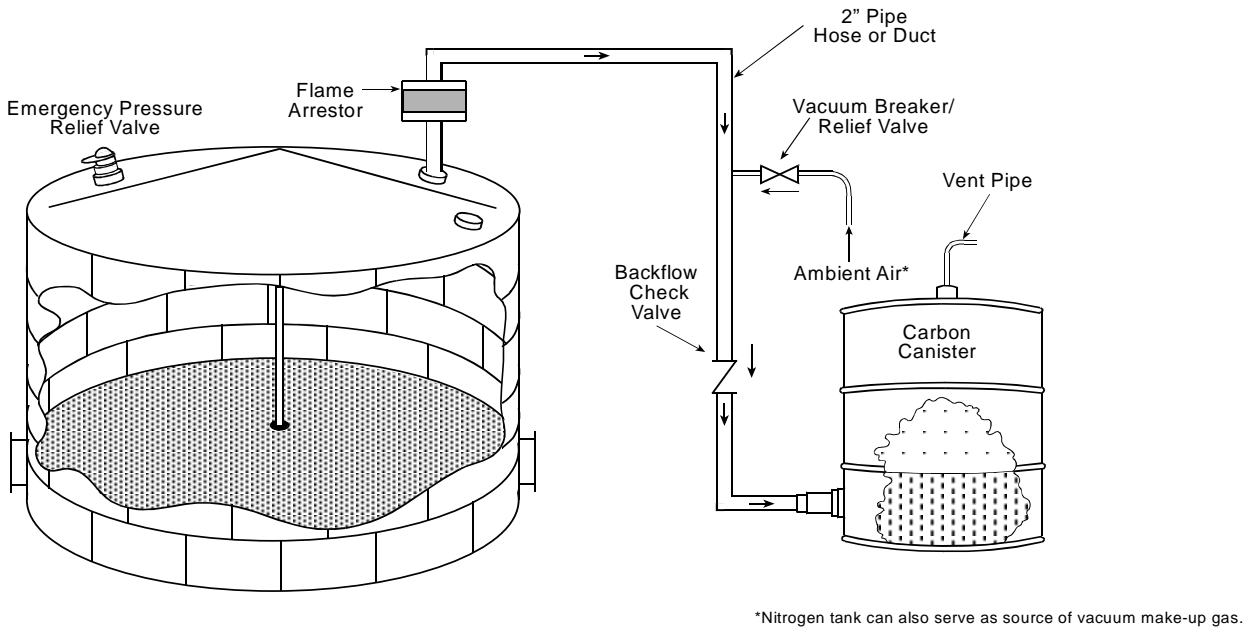

Figure 5-2. Schematic of carbon canister installations with safety devices, configuration B.

This page intentionally left blank.

6.0 Summary and Conclusions

Carbon canisters can safely (and effectively) be used to control organic air emissions from fixed-roof tanks. Safe operation of carbon canisters begins with eliminating or minimizing, to the extent possible, the occurrence of bed fires in carbon canisters. Table 6-1 summarizes conditions that may contribute to carbon bed combustion. Should a carbon fire occur, large scale collateral effects (such as tank explosions) can be prevented by installing appropriate safety devices to confine the fire to the carbon bed and then promptly extinguish it. The basic set of safety components for carbon canister systems used to control organic air emissions from fixed-roof tanks consists of a backflow check valve, a vacuum breaker relief valve, a flame arrester, and an emergency pressure relief valve. Implementation of additional safety measures may be prudent depending on site-specific conditions. Table 6-2 summarizes safety measures that can reduce the incidence of carbon canister bed fires and minimize the impacts in cases when a fire does occur.

Table 6-1. Summary of Conditions Contributing to Bed Fires in Carbon Canisters Used to Control Fixed-Roof Tank Air Emissions

- | |
|---|
| <ul style="list-style-type: none">• Adsorption of high heat generating compounds (e.g., organic sulfur, ketones, aldehydes, or organic acids)• Use of activated carbons or compounds with low ignition temperatures• Back-flow from carbon canister to tank (i.e., tank breathing through the canister)• Low and intermittent gas flow from the tank through the carbon canister not adequate to remove heat generated• Air leaks in valves and other equipment provide sources of oxygen to carbon bed |
|---|

Table 6-2. Summary of Safe Measures for Carbon Canisters Used to Control Fixed-Roof Tank Air Emissions

- Install a check valve to prevent back-flow through carbon bed and eliminate breathing air in through the bed (at night or other times when pumping out). Also, install a vacuum-breaker relief valve upstream of the carbon canister to provide tank air source
- Install a flame arrester to prevent flashbacks from the carbon canister to the tank vapor space in the event of a bed fire
- Install an emergency pressure relief valve to prevent tank rupture due to a plugged carbon bed
- Use a nitrogen gas blanket to prevent combustion
- Pre-wet the activated carbon bed to remove excess heat
- Use activated carbons having high ignition temperatures and low ash characteristics
- Locate carbon canisters where easily accessed for removal but physically isolated from tank being controlled
- Monitor and closely supervise carbon canister startup for early warning of bed oxidation Monitor temperature, CO, and CO₂ levels to check for combustion in the bed
- Inspect and maintain valves and other system components to minimize air leaks (oxygen) into the carbon bed that promote oxidation reactions
- Train facility personnel to respond rapidly to and extinguish carbon bed fires. Overhead deluging with water is an effective means for putting out bed fires

7.0 References

1. U.S. Environmental Protection Agency. December 1997. *Sources and Air Emission Control Technologies at Waste Management Facilities*. Office of Research and Development, Washington, DC.
2. Naujokas, A. 1979. Preventing carbon bed combustion problems. In. *Chemical Engineering Progress. Volume 12: Loss Prevention*, American Institute of Chemical Engineers. New York, NY.
3. Smisek, M., and S. Cerny. 1970. *Active Carbon: Manufacture, Properties and Applications*. Elsevier Publishing Company, Amsterdam.
4. Boiston, D. 1968. Safe study: acetone oxidation. *British Chemical Engineering* 13(1):85-88.
5. Takeuchi, Y., M. Mizutani, and H. Ikeda. 1990. Prevention of activated carbon bed ignition and degradation during the recovery of cyclohexanone. *Journal of Chemical Engineering of Japan* 23(1):68-74.
6. Bowes, P. and A. Cameron. 1971. Self heating and ignition of chemically activated carbon. *J. Appl. Chem. Biotechnology* 21:244-250, September.
7. Henning, K., W. Bongartz, and J. Degel. 1989. *Adsorptive Recovery of Problematic Solvents*. Presented at the Nineteenth Biennial Conference on Carbon Pennsylvania State University, University Park, PA.
8. Hassler, J. 1963. *Activated Carbon*, Chemical Publishing Company, Inc., New York, NY.
9. Harrell, R., J. Sewell, and T. Walsh. 1979. Control of malodorous compounds by carbon adsorption. In. *Chemical Engineering Progress. Volume 12: Loss Prevention*, American Institute of Chemical Engineers. New York, NY.
10. Chapman, M. and D. Field. 1979. Lessons from carbon bed adsorption losses. In. *Chemical Engineering Progress. Volume 12: Loss Prevention*, American Institute of Chemical Engineers, New York, NY.

References

11. Kerr, J. 1998. Letter to J. Gettle, U.S. Environmental Protection Agency, Region 4, Enforcement and Compliance Branch, Waste Management Division. 1998. Information about Investigation and Corrective Measures Related to the January 15, 1998, Carbon canister Incident, Southeastern Chemical, Sumter, SC.
12. Calgon Carbon Corporation. June 29, 1999, Vapor Phase Adsorption and Equipment Bulletin on Ventsorb Canisters, Pittsburgh, PA.
13. Carbtrol. July 1, 1999, Installation Information and Recommendations of Carbon Adsorption Units for Venting Applications, Westport, CT.
14. Carbon Link Corporation. June 30, 1999. Telephone Contact Summary, C. Brockmann, Research Triangle Institute, with B. McMillen, Columbus, Ohio.
15. US Filter Westates. June 30, 1999, Information Concerning Activated Carbon Systems, Red Bluff, CA.
16. See Reference 12.
17. See Reference 13.
18. See Reference 13.
19. Calgon Carbon Corporation, January 30, 2001. Telephone Contact Summary, C. Brockmann, Research Triangle Institute, with C. Nitchman, Pittsburg, Pennsylvania.
20. See Reference 14.
21. See Reference 19.
22. See Reference 13.
23. Perry's Chemical Engineer's Handbook Seventh Edition, Edited by R.H. Perry and D.W. Green, McGraw-Hill, 1997: pp. 26-38 through 26-43.

Appendix A

Additional Sources of Information

This page intentionally left blank.

Additional Sources of Information

- Studies of spontaneous combustion in beds of activated carbon (Hardman, J., P. Street, and C. Twamley. 1980. Studies of spontaneous combustion in beds of activated carbon. *FUEL* 59:151-156.)
- Further Studies of the Spontaneous Ignition Behavior of Activated Carbon (Hardman, J., C. Lawn, and P. Street. 1983. Further studies of the spontaneous ignition behaviour of activated carbon. *FUEL* 62:632-638.)
- Spontaneous Ignition in Carbon Adsorption Beds (Boden, N, C. Cullis, and A. Fish. 1962. Spontaneous ignition in carbon adsorption beds. *J. Appl. Chem.* 145-150.)
- Fire Hazard from Carbon Adsorption Deodorizing Systems (U.S. Environmental Protection Agency. 1997. *Fire Hazard From Carbon Adsorption Deodorizing Systems*. EPA 550-F-97-002e. Office of Solid Waste and Emergency Response, Washington, DC.)
- Fire Hazard from Carbon Adsorption Deodorizing Systems (U.S. Department of Labor. 1997. *Fire Hazard From Carbon Adsorption Deodorizing Systems*. Hazard Information Bulletin. Occupational Safety and Health Administration, Washington, DC.)

This page intentionally left blank.

Appendix B
Naujokas' Tables

This page intentionally left blank.

Table B-1. Bed Oxidation at 125 °C*

	ΔT , °C	CO, ppm	Hot Spot ($\Delta T > 200$ °C)	
			Time, min	Position, cm
Acetone	3	25	—	—
Methyl isobutyl ketone	17	490	—	—
Methyl ethyl ketone	33	2,700	—	—
Diisobutyl ketone	>200	>10,000	145	90
Diethyl ketone	>200	>10,000	62	86
Ethyl butyl ketone	>200	>10,000	75	81
Diacetone alcohol	>200	>10,000	3	24
Cyclohexanone	>200	>10,000	4	20
Acetaldehyde	5	40	—	—
Propionaldehyde	30	3,000	—	—
Butyraldehyde	>200	>10,000	4	70
Acetic acid	7	170	—	—
Propanoic acid	>200	>10,000	17	80
Butyric acid	>200	>10,000	21	80
Butanol	0	<10	—	—
Butyrolactone	0	<10	—	—
Carbon	0	<10	—	—
Cyclohexane	0	<10	—	—
Methyl acetate	0	<10	—	—
Methyl butyrate	0	<10	—	—
Methyl Cellosolve	0	<10	—	—
Tetrahydrofuran	0	<10	—	—

* Naujokas, A. 1979. Preventing Carbon Bed Combustion Problems. In. Chemical Engineering Progress. Volume 12: Loss Prevention, American Institute of Chemical Engineers. New York, NY, p. 131.

Table B-2. Bed Oxidation at 100 °C*

	ΔT , °C	CO, ppm	Hot Spot ($\Delta T > 200$ °C)	
			Time, min	Position, cm
Methyl isobutyl ketone	4	60	—	—
Diisobutyl ketone	4	80	—	—
Ethyl butyl ketone	6	275	—	—
Methyl ethyl ketone	7	200	—	—
Diethyl ketone	11	280	—	—
Cyclohexanone	>200	>10,000	82	46
Propionaldehyde	29	2,200	—	—
Butyraldehyde	>200	>10,000	60	85
Propanoic acid	4	80	—	—
Butyric acid	6	130	—	—

* Naujokas, A. 1979. Preventing Carbon Bed Combustion Problems. In. Chemical Engineering Progress. Volume 12: Loss Prevention, American Institute of Chemical Engineers. New York, NY, p. 131.